

PowerProbe™ 9100-TR



Smaller than the 9300-TR with the same hammer capability. Designed and built for the John Deere 3120 tractor with quick disconnect.

Standard Features

- Adjustable mast
- Long lasting powder-coated finish
- Anodized metal power track
- Electro-hydraulic valves – foot, up-down, side-side and tilt
- Spring loaded pull yoke
- Enhanced control panel
- One year warranty
- Tooling Storage Racks
- 175 ft-lb hydraulic hammer

Convenience/Safety Package

- Hand auger to pre-clear soil boring locations
- Hydraulic oil pressure gauge
- Emergency stop system
- 12 Volt accessory outlet
- Hour meter
- Tooling vise and storage

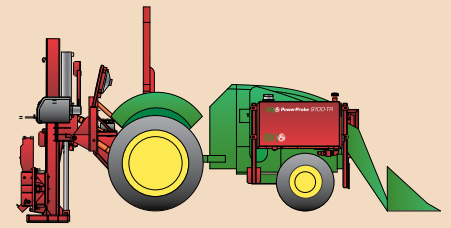

Power

Required Horsepower29.5 hp or higher

Dimensions

Weight app. 4,500 lb
 Height Elevated135"
 Max Cylinder Height126"
 Standard Probe Stroke56"

Hydraulics

Hydraulic Oil Pressure2,500 psi
 Oil Flow16 gpm
 Hydraulic Oil Cooler18,000 BTU single
 Hydraulic Oil Capacity25 gal

Hydraulic Operation

Down Force16,800 lb
 Pull-Up Force25,000 lb
 Head Travel Rate Up6 sec
 Head Travel Rate Down9 sec
 Horizontal Traverse10"
 Foot Vertical Stroke32"

Hydraulic Hammers

Standard Hammer - AR-48175 ft-lb - 1,500 bpm

Auger Drive Head

Optional1,000 ft-lb
 (Upgrade to AR-48 Hammer - No 1,000 Auger Available)

call for pricing



PowerProbe™ 9100-TR

PowerProbe™ 9100-TR

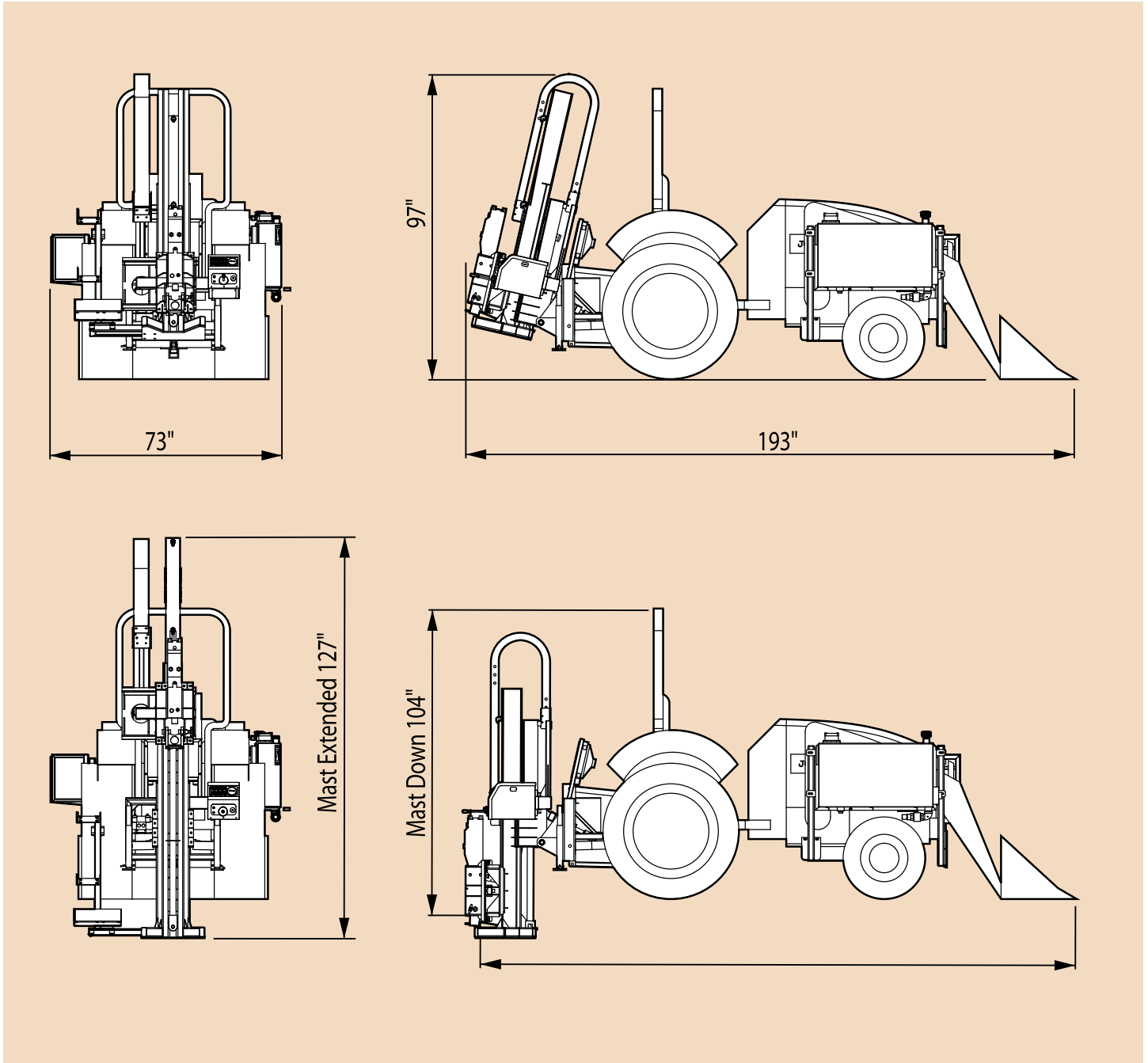

Options and Accessories

- Regen System



Mounting Options

- 3120 John Deere Tractor